

CLKA-D

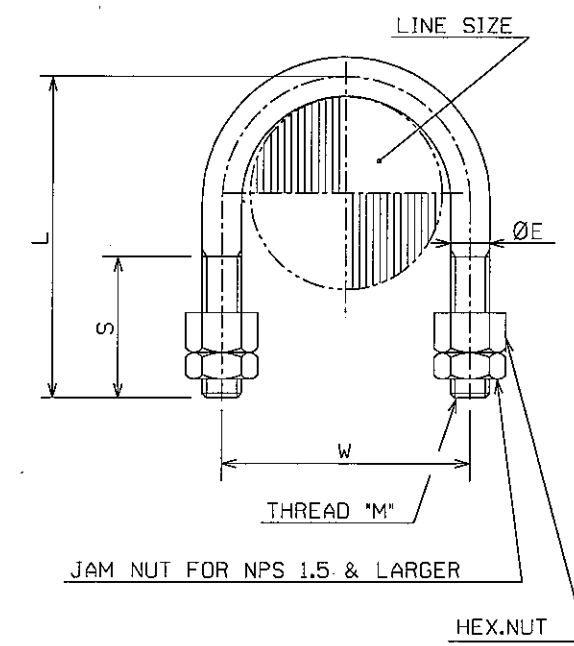

CLKB-D

TYPE	LINE SIZE NPS 'D'	DIMENSIONS				THREAD	
		E	W	L	S	M	
CLKA/B	0.5	8	32	55	30	5/16	UNC
CLKA/B	0.75		38	60	32		
CLKA/B	1		44	75	40		
CLKA/B	1.5	10	61	85	45	3/8	UNC
CLKA/B	2	13	76	105	50	1/2	UNC
CLKA/B	3		104	130			
CLKA/B	4		130	160			
CLKA/B	6	16	187	215	60	5/8	UNC
CLKA/B	8		238	265			
CLKA/B	10		292	320			
CLKA/B	12	19	345	375		3/4	UNC
CLKA/B	14		377	410	70		
CLKA/B	16	22	430	465	80	7/8	UNC
CLKA/B	18	25	484	515	90	1	UNC
CLKA/B	20		535	570			
CLKA/B	22		587	620			
CLKA/B	24		637	670			
CLKA/B	26		688	720			
CLKA/B	28		739	770			
CLKA/B	30		789	820			

FOR CONSTRUCTION

- NOTE:
- (1) TYPE-CLKB SHALL BE USED FOR FIXING.
  - (2) USE OF U-BOLT SUPPORTS FOR VERTICAL LINES IS LIMITED TO NPS 18 AND SMALLER LINES WITH DESIGN TEMPERATURE OF -29°C TO 149°C
  - (3) U-BOLT SUPPORTS FOR HORIZONTAL PIPING CLAMPED TO THE SIDE OF STRUCTURAL MEMBERS ARE LIMITED TO NPS 1/2 AND SMALLER.
  - (4) U-BOLT SHALL BE SELECTED AS BELOW.
- | PIPE MATERIAL      | U-BOLT MATERIAL |
|--------------------|-----------------|
| CS                 | A36             |
| LTCS & ALLOY STEEL | 304S.S. (*)     |
| NON-FERROUS        | 304S.S. (*)     |
- (\*) : DUAL GRADE MATERIAL OF 304 AND 304L S.S. MAY BE USED.

DWG NO.	TITLE				
REFERENCE DRAWINGS					
E5	ISSUE FOR CONSTRUCTION				22.AUG.06
E4	ISSUE FOR CONSTRUCTION	Y.Morimoto	K.Usuki	F.Sakai	02.MAY.06
E3	ISSUE FOR CONSTRUCTION	Y.Morimoto	K.Usuki	F.Sakai	15.FEB.06
E2	ISSUE FOR CONSTRUCTION	Y.Morimoto	K.Usuki	F.Sakai	30.SEP.05
E1	ISSUE FOR CONSTRUCTION	Y.Morimoto	K.Usuki	F.Sakai	MAY.2005
C1	ISSUE FOR REVIEW	S.Nishiyama	K.Usuki	F.Sakai	MAR.11.05
NO.	DESCRIPTION	BY	CHKD	APVD	APVD
REVISIONS					
REV	DATE	APPROVED			
ISSUED FOR CONSTRUCTION					
DATE	MAR.11.05	MAR.11.05	MAR.11.05	MAR.11.05	
BY	MPM	S.Nishiyama	K.Usuki	F.Sakai	
	DRAWN	DSGND	CHKD	APVD	APVD
ALL RIGHTS RESERVED					
THIS DOCUMENT IS THE PROPERTY OF QATARGAS II AND CONTAINS INFORMATION WHICH IS PROPRIETARY. THIS INFORMATION IS TO BE HELD IN CONFIDENCE. NO DISCLOSURE OR OTHER USE OF THIS DOCUMENT IS TO BE MADE WITHOUT THE PRIOR WRITTEN CONSENT OF QATARGAS II.					
<b>QATARGAS II DEVELOPMENT PROJECT</b>					
Contract No. GTC-QGII-ONS-15					
		Qatar Liquefied Gas Company Limited (II)			
TITLE					
CLKA-D / CLKB-D					
U-BOLT					
SCALE					
PROJECT			JOB NO. 49222		REVISION
DRAWING NO.		QGX/20/00/MP/DR/TD/002		E5	
SHEET NO.		255			